

MARATHON FIRE DOOR KIT

FOR FIRE DOORS UP TO 90KG

**Designed for use solely in conjunction with
P C Henderson Marathon S3,S4,S5 or S6 gear sets**

STANDARD KIT SIZES

The MARATHON Fire Door Kit (FDK 1) is produced in one standard size for use with doors weighing up to 90kg max. and must be used with a MARATHON set 'S3' for doors 750 - 900mm wide or set 'S4' for doors 900 - 1050mm wide or set 'S5' for doors 1050mm - 1200mm wide or set 'S6' for doors 1200mm - 1500mm wide. (S3/S4/S5/S6 not included in Fire Door Kit). For doors below 750mm or over 1500mm wide or over 90kg in weight, please consult P C Henderson Limited.

OPERATION

The easily operated sliding door is returned automatically to the closed position after each operation by the smooth operation of the counterbalance weights.

DOOR SEALS

It is required that intumescent fire seals be incorporated into the door framework to contain the fire within the fire area (do not use smoke seals as this will hinder self closing action - seals not supplied by P C Henderson Limited).

FIRE RATING

The Marathon Fire Door Kit (FDK1) is a system developed as part of a half hour sliding fire door assembly to BS 476: Part 22: 1987, and should be installed on the non-fire risk side of an aperture.

The assembly must be fitted with a solid core FD30, or FD60, timber based fire door positively appraised by Warrington Fire Research or CERTIFIRE approved.

Assessment report WFRC No. C118443 confirms that a sliding fire door assembly, fitted in accordance with these instructions, will offer 30 minutes of fire protection in accordance with BS 476: Part 22: 1987, (ref: report Warres No. 40991).

**For further assistance please contact
P C Henderson Limited Technical Department**

HENDERSON

A company in the Cardo Group

P.C. Henderson Limited

Durham Road, Bowburn, County Durham DH6 5NG, England.
www.pchenderson.com

P.C. Henderson (Ireland) Ltd

Weat Link Industrial Estate, Kylemore Road, Dublin 10, Eire, Telephone: 01626 0444 Facsimile: 01626 0455
www.pchenderson.ie sales@pchenderson.ie

Customer Services Department

Telephone: 44(0)191 377 7345 Facsimile: 44(0)191 377 3116 e-mail:sales@pchenderson.com

Export Department

Telephone: 44(0)191 377 0701 Facsimile: 44(0)191 377 0755 e-mail:international@pchenderson.com

MARATHON FIRE DOOR KIT

FOR FIRE DOORS UP TO 90KG

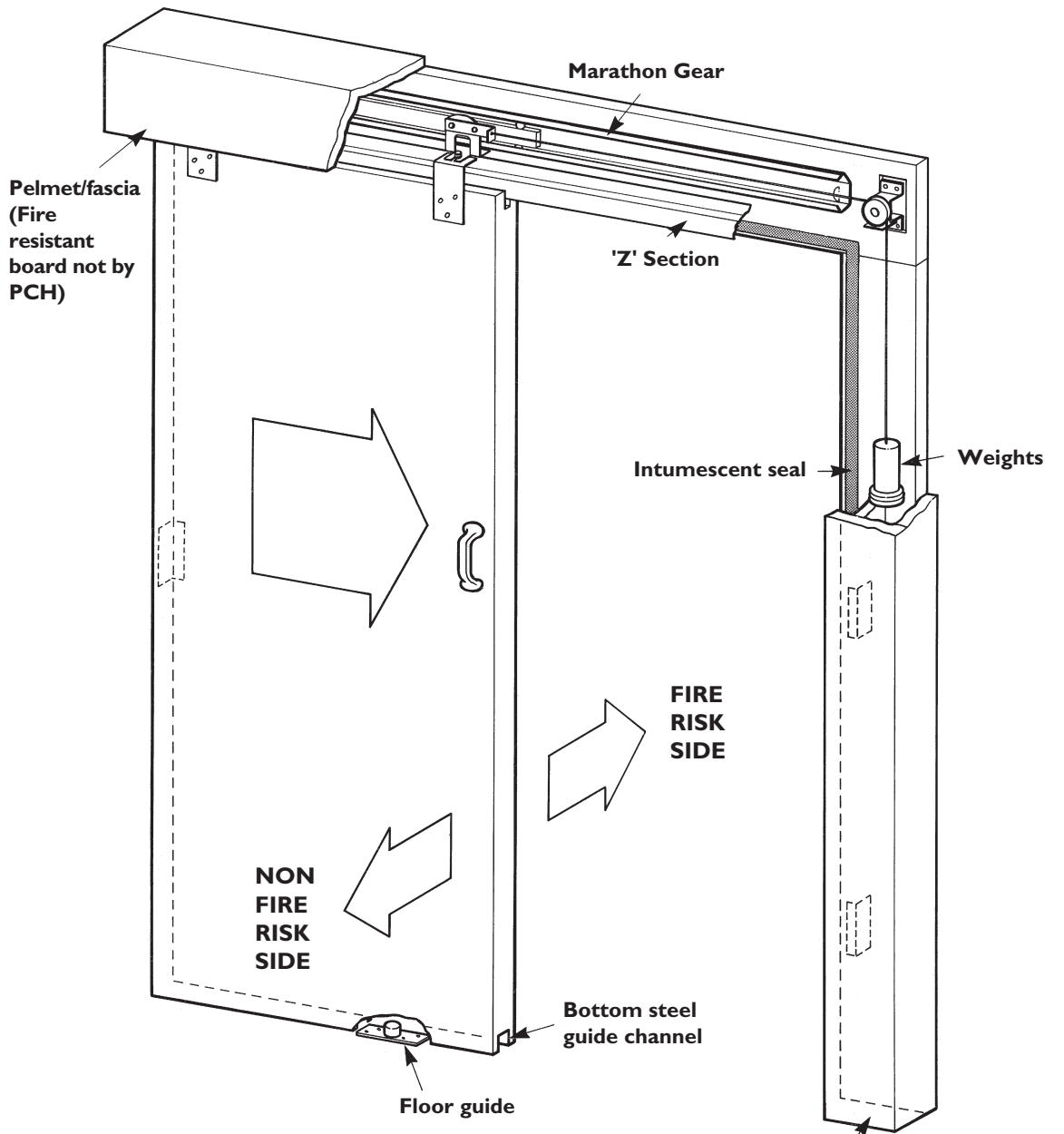

WARNING:
Door must be free to close at all times. Do not retain in open position.
Be aware of the area the door moves through during its operating cycle.
Keep people and objects out of the way at all times.