

SIM100 KIT FOR HUSKY

FOR MAXIMUM DOOR WEIGHTS OF 100kg EACH

SIMULTANEOUS ACTION KIT FOR BI-PARTING DOORS

APPLICATION

- ▶ Designed to be used in conjunction with a pair of Husky 50, Husky 100 or Pocket Doors Kits (PDK range)
- ▶ For internal partition bi-parting timber doors
- ▶ This kit can be retro fitted to existing installations
- ▶ Ideal for pairs of doors opening into pocket walls
- ▶ For use with either steel or aluminium Husky track
- ▶ Polypropylene coated cable for quiet operation
- ▶ Spring tension providing smooth operation
- ▶ Pulley wheels complete with bearings to provide reliable operation

DOOR & GEAR SPECIFICATION

- ▶ Simultaneous Action Kit
- ▶ Minimum Door Weight
- ▶ Maximum Door Weight
- ▶ Maximum Door Thickness
- ▶ Maximum Door Width
- ▶ Door Material

Husky 50

SIM100 x I
25kg
50kg
25-50mm
1250mm
Timber

Husky 100

SIM100 x I
25kg
100kg
25-50mm
1250mm
Timber

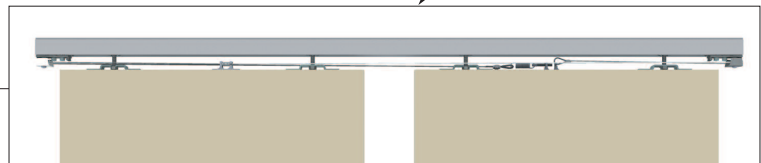
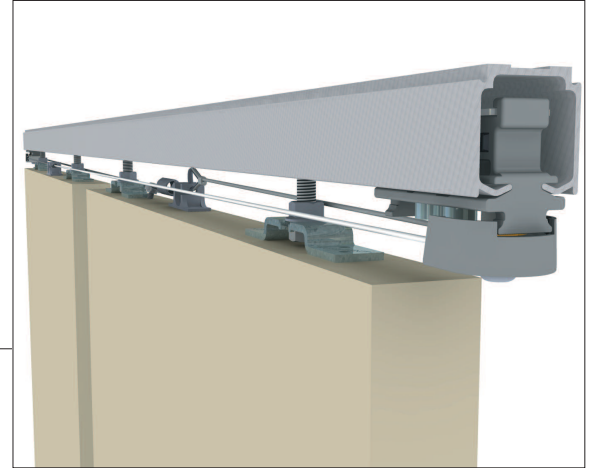

HENDERSON

SIMULTANEOUS ACTION KIT

Diagram 1. Left hand clip stop and pulley assembly

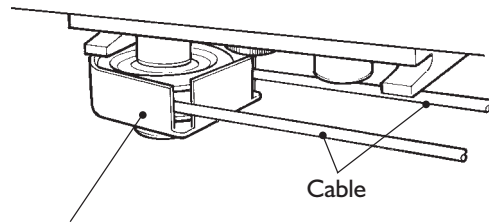

Clip stop end bolt removed and replaced with extended bolt, spacer and pulley assembly

Diagram 2. Right hand clip stop and pulley assembly

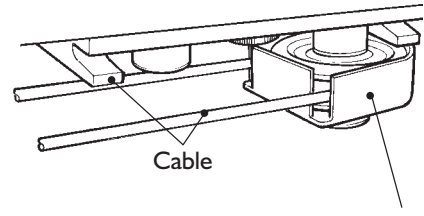

Clip stop end bolt removed and replaced with extended bolt, spacer and pulley assembly

Elevation view of system

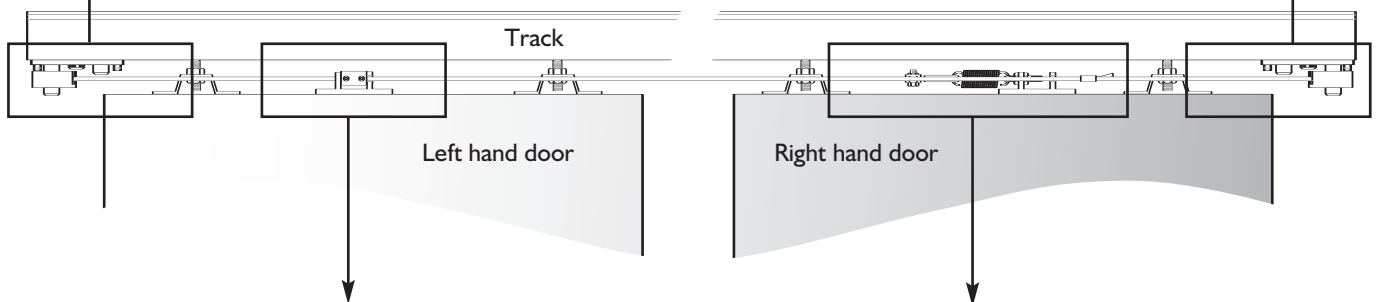

Diagram 3. Cable anchored to left hand door

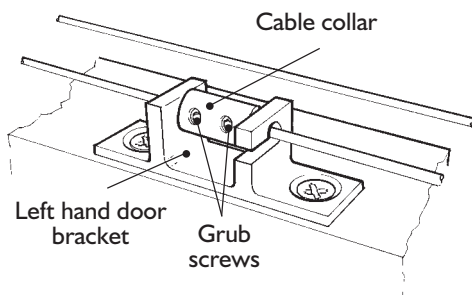

Diagram 4. Cable anchored to right hand door, tensioning and adjustment bolt.

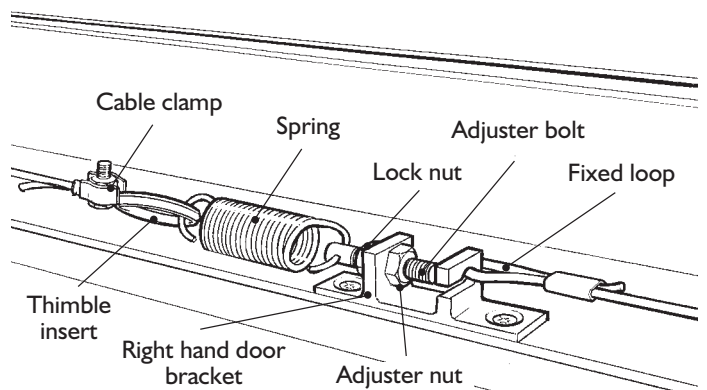

Diagram 5.

