



CI/SB

(31.54) Xct7

ISSUE 1

SOL250

SOLTAIRE 250

TOP HUNG STRAIGHT SLIDING DOOR SYSTEM FOR DOORS UP TO 250kg EACH

APPLICATIONS

- ▶ Manufactured from high grade 316 stainless steel within anodised aluminum track.
- ▶ This reliable system is extremely durable and ideal for coastal applications or heavy use.
- ▶ Ideal for areas requiring a high level of corrosion resistance.
- ▶ Designed for interior and exterior doors up to 250 kg.
- ▶ Ideal for residential or commercial applications.
- ▶ Designed to accommodate multiple doors which can slide to either side or all to the same side.
- ▶ Hangers available for timber or metal doors.
- ▶ The track can be soffit fixed or face fixed to give flexibility of installation.

DOOR SPECIFICATION

Max panel weight	250 kg
Max panel thickness	48mm
Min panel thickness	35mm
Max panel height	3300mm

GEAR SPECIFICATION

Track	Anodised aluminium (25 microns) available in lengths <i>Soffit fix spacing 900mm centres (maximum)</i>	250/2000A, 250/2500A, 250/3000A, 250/4000A, 250/5000A & 250/6000A
--------------	---	---

Brush strips	Available in black in 4 brush heights, by the metre	BS10, BS15, BS20, BS25(mm)
---------------------	---	----------------------------

Brackets	Face fixed stainless steel	1/SS
	Double face fixed stainless steel bracket (heavy) <i>Starting 20mm from end of track fix at 900mm centres (maximum)</i>	5H/SS

Hangers	2 required per door	
	Timber doors	- corner plate fixing 52/250/SS - saddle plate fixing 53/250/SS - (concealed) plate fixing 57/250/SS
Metal doors	- angled frame door fixing	56/250/SS
	- box frame fixing	56X/250/SS
	- (concealed) plate fixing	57/250/SS

Guides	Timber doors	- (concealed) fixing with SS bearing 106H SS/94 - wall mounted guide 102 SS/94 - for multiple runs of doors use 102 SS/94
	Metal doors	- box section metal door - long 104PX/89 - box section metal door 104P/89

Channels	Aluminium (2000, 2500, 3000 & 6000mm)	94X
	Stainless steel (3000mm length only)	89SS
	Brass (1500mm and 3000mm length only)	94
	Galvanised steel (1800, 2000, 2500 & 3000mm)	89
	Polypropylene channel	94P
	Aluminum supporting channel for polypropylene	94SC

* Can be used with 97 galvanised steel channel for heavier doors

Track Stop	HH5/SS
-------------------	--------

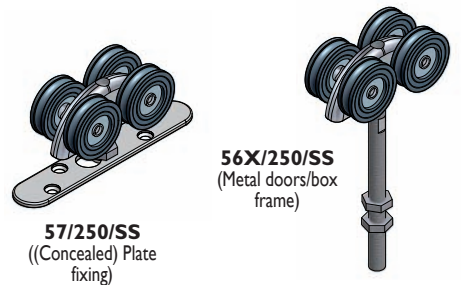
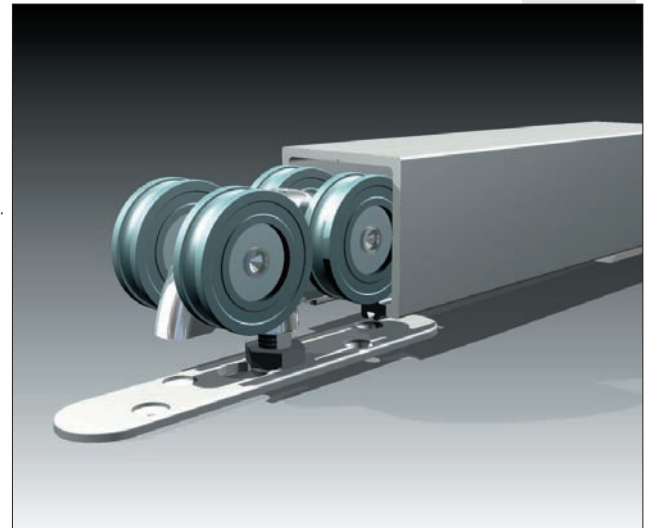

57/250/SS
((Concealed) Plate fixing)

56X/250/SS
(Metal doors/box frame)

56/250/SS
(Metal doors/angle frame door fixing)

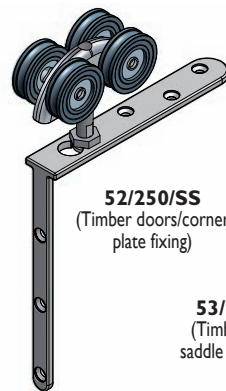

52/250/SS
(Timber doors/corner plate fixing)

53/250/SS
(Timber doors/saddle plate fixing)

HH5/SS
(Track stop)

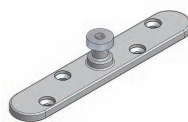

106H SS/94
(Guide)

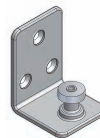

102 SS/94
(Guide)

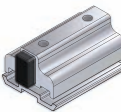

1/SS
(Bracket)

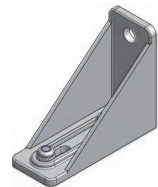

5H/SS
(Bracket)



SOLTAIRE 250

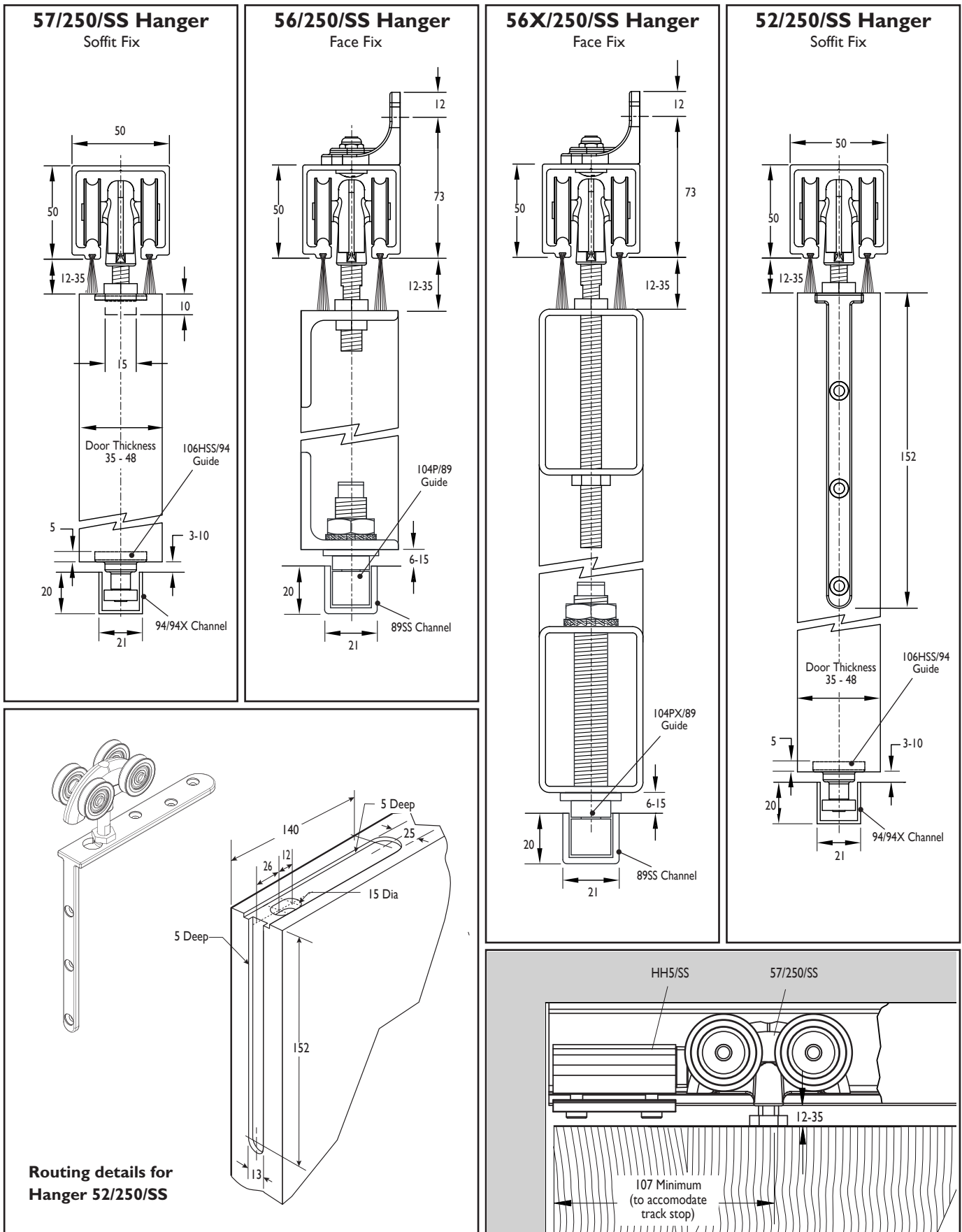

(All dimensions are in mm.)

HENDERSON

P C Henderson Limited, Durham Road, Bowburn, County Durham DH6 5NG, UK. Web: www.pchenderson.com
 Customer Services Department: Tel: +44 (0)191 377 7345 Fax: +44 (0)191 377 3116 Email: sales@pchenderson.com
 Export Department: Tel: +44 (0)191 377 7346 Fax: +44 (0)191 377 0755 Email: international@pchenderson.com